

HIGH TEMPERATURE PIEZOELECTRIC ACCELEROMETER (HTPE)

Model 6243M8/6243M9



Product description

Parker Meggitt's Models 6243M8 and 6243M9 piezoelectric accelerometers are designed specifically for use in extremely high temperature environments such as aircraft and ground-based gas turbines. These accelerometers are designed for continuous operation at +1000°F (+538°C). The small size and light weight of these accelerometers facilitate installation in cramped locations with minimal structural support.

Models 6243M8 and 6243M9 incorporate Parker Meggitt's MC2 shear mode crystal. The 6243M8 has its sensitive axis located in line with the mounting screw. The 6243M9 has its sensitive axis located perpendicular to the mounting screw. The sensing elements and integral shield are isolated from the case. The accelerometer output is terminated through a 10-32 coaxial receptacle. The dash numbers at the end of the model number define an integral coaxial high temperature softline cable that is installed on the 10-32 connector with lock wires and high temperature adhesive.

Model number definition:

6243MX = basic model number

6243M8 = sensitive axis in line with mounting bolt

6243M9 = sensitive axis perpendicular to mounting

Key features and benefits

- +1000°F (+538°C) operation
- High temperature softline cable provides easy cable routing in cramped locations
- Hermetically sealed (accelerometer)
- No pyroelectric or thermal velocity spiking
- Single bolt mount
- Ground isolated
- RoHS compliant

Applications

- Aircraft and gas turbine engine monitoring
- Test cell vibration measurements
- Nuclear applications



Parker Meggitt Defense Systems
9801 Muirlands Blvd.
Irvine, CA 92618
+1 (949) 465 7700
www.meggittdefense.com

HIGH TEMPERATURE PIEZOELECTRIC ACCELEROMETER (HTPE)

Model 6243M8/6243M9

Specifications

The following performance specifications are typical values, referenced at +75°F (+24°C) unless otherwise noted.

Dynamic characteristics	Units	6243M8/M9
Charge sensitivity		
Typical	pC/g	5.5
Tolerance	pC/g	±0.5
Frequency response Resonance frequency		
Typical	kHz	11
Minimum	kHz	9
Typical amplitude response [1][2]		
±5%	Hz	1 to 2000
±10%	Hz	1 to 3000
±3dB	Hz	1 to 6000
Temperature response		See typical curve
+1000°F (+538°C) max/min	%	±15
Transverse sensitivity	%	≤5
Amplitude linearity per 500g, 0 to 2000 g	%	1
Electrical characteristics		
Output polarity	Acceleration in direction of arrow marked on unit produces positive output	
Resistance		
Over temperature range [3]	kΩ	>200
Capacitance		
Transducer, excluding cable	pF	50
Dielectric strength	V	500
Grounding		Signal return isolated from case
Environmental characteristics		
Temperature range		
Transducer and cable, continuous	°F (°C)	-65 to +1000 (-55 to +538)
Humidity (transducer)		Hermetically sealed
Sinusoidal vibration limit	g	500
Shock limit	g	2000
Cable bend repeatability		200 bends, minimum
Physical characteristics		
Dimensions		See outline detail
Weight excluding cable material	grams (oz)	30 (1.1) Case Inconel
Connector (End of attached cable)		Male 10-32 coaxial
Mounting torque	lbf-in (Nm)	18 (2)



**Defense
Systems**

HIGH TEMPERATURE PIEZOELECTRIC ACCELEROMETER (HTPE)

Model 6243M8/6243M9

Calibrations Supplied

Charge sensitivity	pC/g	
Frequency response	%	50 Hz to 3000 Hz
Transverse sensitivity	%	
Capacitance	pF	

Accessories

SUPPLIED: EH471 MOUNTING SCREW, 10-32 X .75 in, 12 PT
OPTIONAL: Model 1001-ZZZ Cable assembly, +550°F (288°C)/ 3075M6-ZZZ/3075M6-ZZZ-US Cable assembly, 900°F (+482°C)
OPTIONAL: Model 3076A-ZZZ [+1000°F (+538°C) Flexible]
OPTIONAL: Model 1772-1 Remote charge converter
OPTIONAL: Isolator Pad 47091, EH875 Mounting Screw [keeps unit 200 °F cooler for 30 minutes)

Notes

1. Frequency response is controlled by the resonance characteristics of the transducer.
Estimated calibration errors are $\pm 1.5\%$ to 900 Hz and 2.5% from 900 Hz to 5000 Hz.
2. Low-end response of the transducer is a function of its associated electronics.
3. The electrical resistance of piezoelectric materials decreases with an increase in temperature but remains above $200\text{K } \Omega$ at $+1000^\circ\text{F}$ ($+538^\circ\text{C}$).
4. For cable lengths of less than 12 inches (0.30 m), the maximum operating temperature is $+900^\circ\text{F}$ ($+482^\circ\text{C}$).

HIGH TEMPERATURE PIEZOELECTRIC ACCELEROMETER (HTPE)

Model 6243M8/6243M9

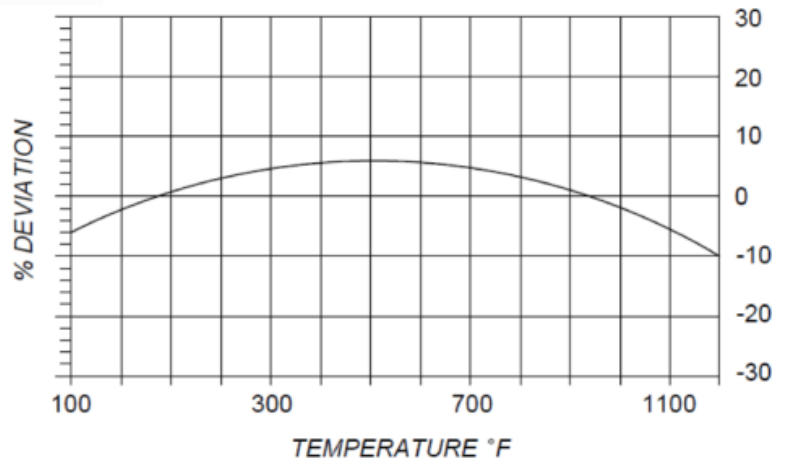
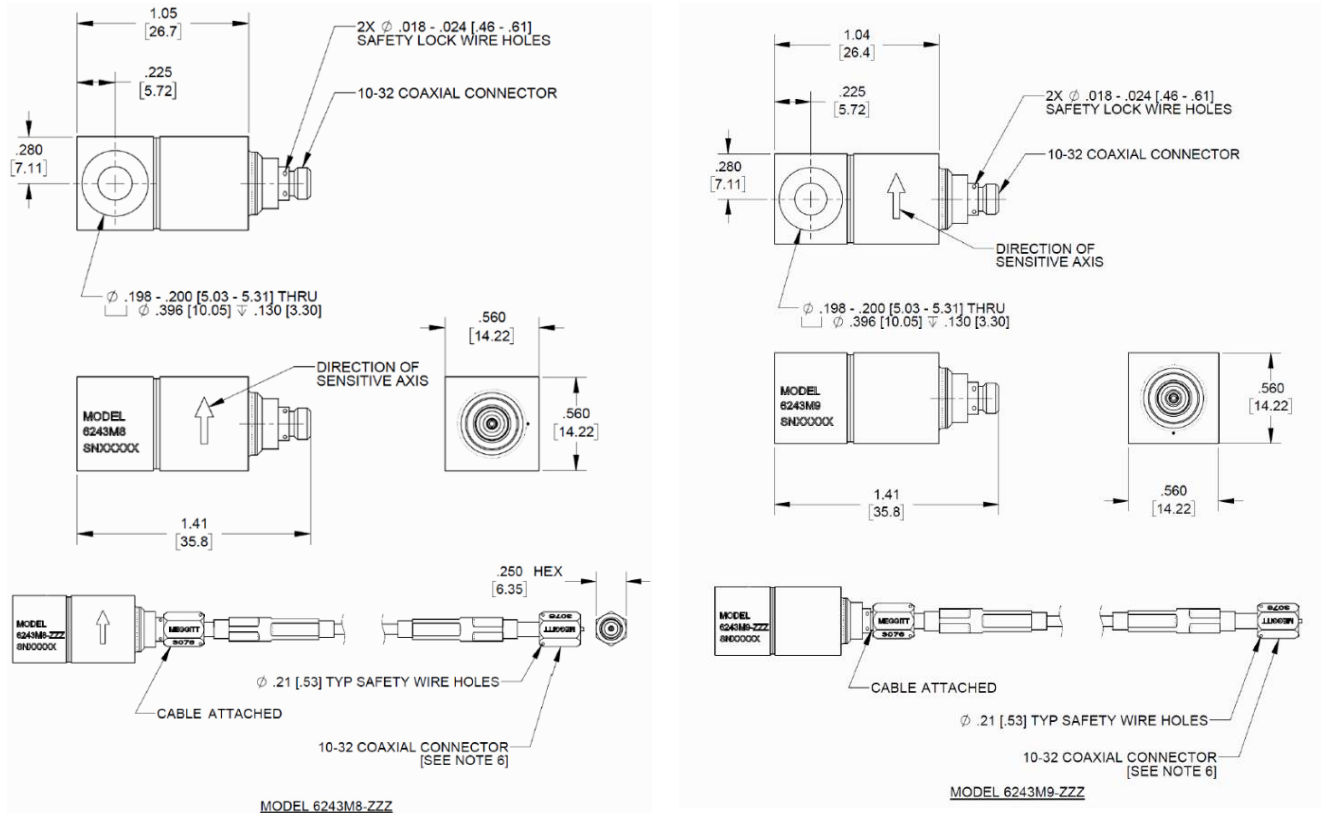

Continued product improvement necessitates that MEGGITT reserve the right to modify these specifications without notice. MEGGITT maintains a program of constant surveillance over all products to ensure a high level of reliability. This program includes attention to reliability factors during product design, the support of stringent Quality Control requirements, and compulsory corrective action procedures. 010121



Note: Due to continuous process improvement, specifications are subject to change without notice. TCO Review # 334