

PATHFINDER ENVIRONMENTAL CONTROL UNIT

Model 3226

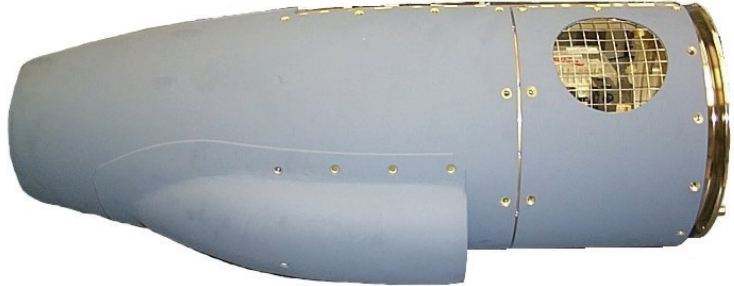

Product description

The F-16 Pathfinder pod Environmental Control Unit (ECU) is very compact, extremely light weight and is capable of providing electronic thermal management throughout the flight envelope of a high performance aircraft such as the F-16.

The ECU supplies 1.0 kilowatt of cooling in a package that is 9.75 inches in diameter and 26 inches in length, and is less than 60 lbs. in overall weight.

The entire flight envelope performance was modeled through a computer program that provided real time data on all of the refrigeration components. These included the compressor, condenser, evaporator and even the aerodynamic shaping of the ram air scoop to maximize performance with no weight excesses.

The coolant flow circuit design is straight forward and Parker Meggitt Defense Systems utilized finite element computer modeling in establishing the ECU structure to be lightweight and yet robust enough to handle aerodynamic and structural loads. To enhance pod maintainability and servicing requirements, an access panel was included within the weight and structural integrity constraints.

Under contract with Lockheed Martin, Parker Meggitt Defense Systems is proud to be a part of the F-16 Pathfinder pod team.

Key features and benefits

- High performance, endurance proven, rotary vane compressor assembly
- Accessible structural design for ground servicing and diagnostic data acquisition
- Aerodynamic ram air scoop designed for efficient flight performance
- Bypass cooler design for optimized thermal performance in flight
- Coolant service ports to “plug in” GSE cooling carts for in-hangar/laboratory operation
- Ground mode operation capability

Applications

- F-16 Electronic thermal management



Parker Meggitt Defense Systems
9801 Muirlands Blvd.
Irvine, CA 92618
+1 (949) 465 7700
www.meggittdefense.com

PATHFINDER ENVIRONMENTAL CONTROL UNIT Model 3226

| Specifications | |
|--------------------------|---|
| Capacity | 1000 watts (flight operations) 800 watts (ground operations) |
| Refrigerant | R-124 |
| Cooling media: | PAO, 0.70 gpm, minimum |
| PAO delivery pressure | 100 psid |
| PAO delivery temperature | 86° F maximum |
| Electrical power | < 2200 VA, 115 Vac, 3 ph, 400 Hz |
| ECU weight | 56 pounds |
| ECU envelope | diameter = 9.75 in, length = 26 inches |

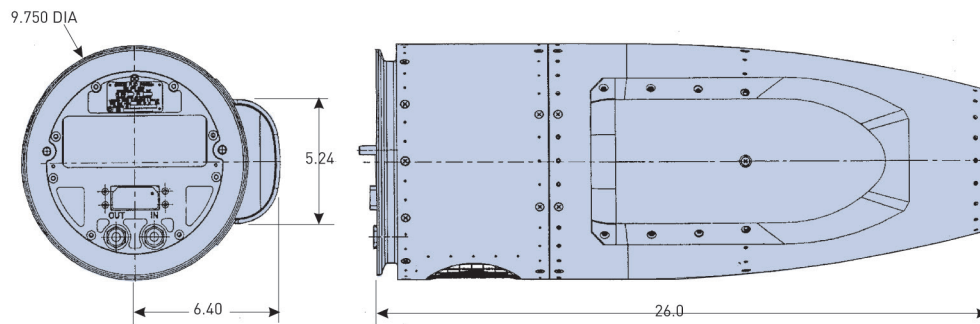

Note: Due to continuous process improvement, specifications are subject to change without notice. TCO Review # 126