

## DATA SHEET

# Gas Turbine Accelerometer

Model 6222M59

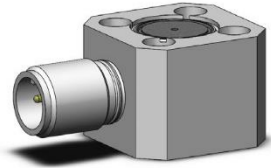

## 01 Description

The MEGGITT Model 6222M59 Accelerometer is designed to be insensitive to random, non-vibrational inputs. Fully radiation resistant, it is also sturdy enough to withstand adverse installation, maintenance and operational environments on jet engines.

The transducer utilizes MEGGITT crystal body in the shear mode to significantly reduce pyroelectric and base strain output while maintaining high mounted resonance.

The device is hermetically sealed against environmental contamination and is constructed of welded stainless steel. It is electrically case isolated with the crystal element isolated from the case and produces a differential output through a 2 pin connector.

## 02 Key features and benefits

- Rugged hermetic design
- Balanced differential output
- Ground isolated
- RoHS compliant

## 03 Applications

- Gas-turbine monitoring

## 04 Contact

1-833-HITEMP1  
TMCSR.MSSOC@meggitt.com

## DATA SHEET

# GAS TURBINE ACCELEROMETER, Model 6222M59

## 05 Specifications

The following performance specifications are typical values, referenced at +75°F (+24°C) unless otherwise noted.

### Performance characteristics

Charge sensitivity at 100 Hz	50 pC/g ±5%
Resonant frequency	20 kHz minimum
Charge sensitivity deviation vs frequency	±5% maximum, 20 Hz to 4 kHz
Charge temperature response	±5% from +30°F (-1°C) to +450°F (232°C)
Transverse sensitivity	3% maximum
Amplitude linearity	Sensitivity increases approximately 1% per 500 g 0 to 2000 g

### Electrical

Internal Capacitance	2800 pF ±400 pF
Transducer Capacitance (Either Signal Lead to Case)	Either signal lead to case will be less than 30 pF. The unbalance between signal leads will be 2 pF maximum.
High Potential	Withstand 110 Vrms, 60 Hz ac from each pin to case for 30 seconds without breakdown
Internal Resistance (All Points) at 100 Vdc	1000 MΩ 50 MΩ minimum at 450°F (232°C) [4]
Insulation Resistance	100 MΩ minimum over the entire temperature range

### Environmental characteristics

Temperature range	-65°F (-53°C) to +500°F (260°C)
Shock	1000 g pk in any direction
Vibration	200 g pk sinusoidal
Leakage	The accelerometer and connector are hermetically sealed Leak rate shall be less than $10^{-4}$ cc/sec of He at 15 psi

### Physical characteristics

Case material	Stainless Steel
Connector	Receptacle that mates with MS3106R-10SL-4S plug assembly
Weight	0.33 pounds

### Calibrations supplied

Charge sensitivity	pC/g at 100 Hz at 2 g peak
Transducer capacitance	pF measured at 1000 Hz
Internal resistance	Measured at 100 Vdc
Insulation resistance	Measured at 100 Vdc
Frequency response	20 Hz to 350 Hz, referenced at 100 Hz
Leakage	Leak rate shall be less than $10^{-4}$ atmospheric cc/second

## DATA SHEET

# GAS TURBINE ACCELEROMETER, Model 6222M59

## 06 Outline details

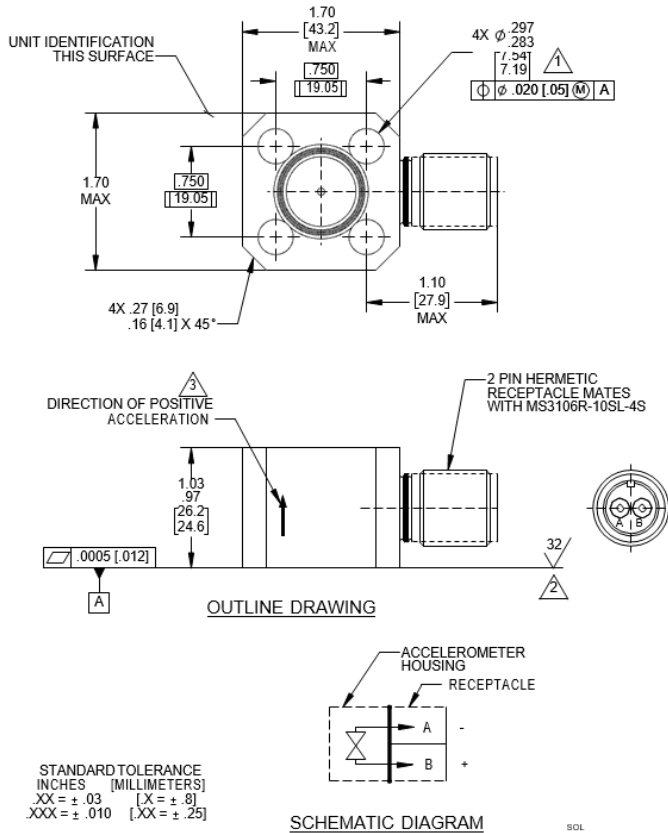

### Notes:

1. Mounting stud or bolt torque range to be 94-100 inch-lbs.
2. Surface that interfaces with accelerometer should be flat to .001 in/in, 63 micro inches RMS maximum surface roughness, and to be clean and free of foreign material.
3. When accelerometer is subjected to an acceleration in the direction shown, pin "B" will be electrically positive.
4. Prolonged exposure at maximum temperatures may decrease the return to room temperature resistance to as low as 50 M $\Omega$ , but will not degrade the overall performance of unit. All units processed to initially meet 1 G $\Omega$  at room temperature.



Continued product improvement necessitates that MEGGITT reserve the right to modify these specifications without notice. MEGGITT maintains a program of constant surveillance over all products to ensure a high level of reliability. This program includes attention to reliability factors during product design, support of stringent Quality Control requirements, and compulsory corrective action procedures. 060724

Note: Due to continuous process improvement, specifications are subject to change without notice. TCO Review #331