

HIGH TEMPERATURE HARDLINE CABLE ASSEMBLY

Model 3075M6



Product description

The Parker Meggitt model 3075M6 is a low noise hardline cable assembly for use in high temperature environments. It is hermetically sealed for resistance to corrosion, humidity and other environmental contaminants. The outer jacket is constructed of 304L stainless steel and covered with a fiberglass sheath to prevent inadvertent grounding. This cable has a history of long-term reliability in both high temperature and nuclear reactor environments.

Both cable assembly ends are terminated into a glass fired 10-32 connector providing unparalleled strength and hermeticity. An optional 10-32 to 10-32 high temperature cable joiner is available (model 33268) for conjoining two 3075M6's into a single unit.

Model number definition:

3075M6-ZZZ

3075M6= basic model number

3075M6-ZZZ-US = Made in USA

ZZZ = cable length in inches

Key features and benefits

- Operating temperature to +900°F (+482°C)
- Rugged and bendable
- Full fiberglass sleeve to prevent inadvertent grounding
- Hermetically sealed
- RoHS compliant

Applications

- For use with high temperature piezoelectric accelerometers
- Nuclear reactor environments



Parker Meggitt Defense Systems
9801 Muirlands Blvd.
Irvine, CA 92618
+1 (949) 465 7700
www.meggittdefense.com

HIGH TEMPERATURE HARDLINE CABLE ASSEMBLY

Model 3075M6

Specifications

The following performance specifications are typical values, referenced at +75°F (+24°C) unless otherwise noted.

	Units	3075M6
Connectors		
Connector 2	in (mm)	10-32 NF, 0.230 dia. (5.84)
Dielectric material		Glass
Pin material		304L stainless steel
Housing material		304 stainless steel
Torque (1)	lb-in (Nm)	Finger tight to 1.5 (0.17)
Weight per connector	gms	1.65
Lock wire holes		Yes
Cable		
Outer jacket and conductor		304L stainless steel
Center conductor material		Nickel
Dielectric		MgO
Outer sleeving		Fiberglass
Diameter	in (mm)	0.070 (1.76)
Weight	gram/ft	7.5
Bend radius (3)	in (mm)	0.75 (19)
Environmental		
Maximum temperature cable and plugs	°F (°C)	900 (482)
Humidity		Hermetic
Integrated Gama flux	rad.	6.2×10^{10}
Integrated neutron flux	N/cm ²	3.7×10^{18}
Electrical		
Insulation resistance, room temperature (2)	GΩ	200
Insulation resistance at 900°F (482°C)	MΩ	10
Cable capacitance (2)	pF/ft.(mtr)	63 (206)
Optional Accessory		
Model 33268 In-line cable adaptor rated to 1000°F (537°C). Allows connecting coaxial cables to one another.		
Notes		
1. For high g shock and vibration the knurled nut should be tightened beyond finger tight. Use of the lock wire holes is also recommended to prevent the threads from backing out.		
2. These parameters are 100% tested		
3. STEP file available on request		
4. Compacted MgO surrounds the center conductor. The outer sheath is made of a stiff material. Both of these factors prevent stressing thus the hardline cable is inherently low noise by design.		

HIGH TEMPERATURE HARDLINE CABLE ASSEMBLY

Model 3075M6

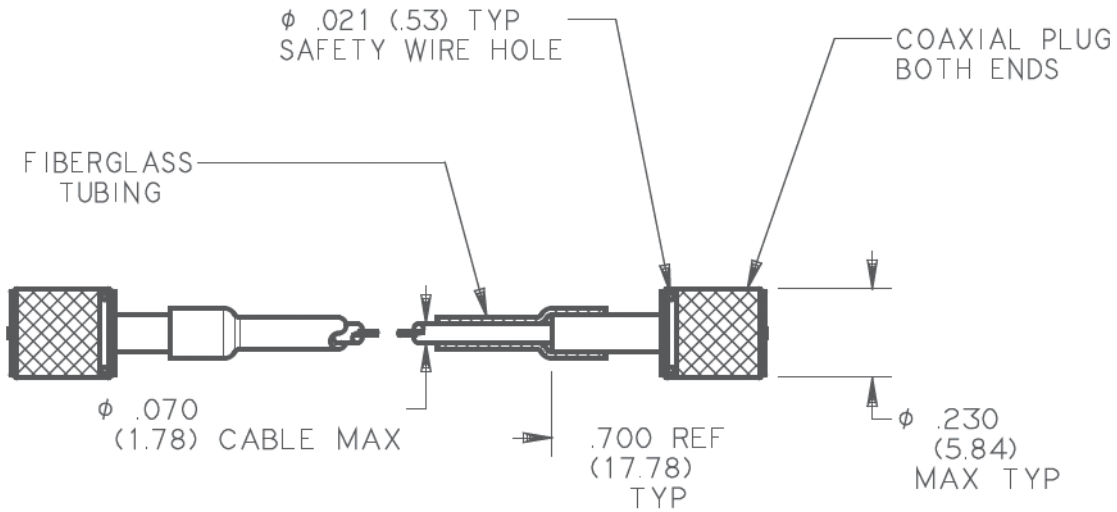

LENGTH TOLERANCE TABULATION: Standard cable lengths in inches: 36, 60, 120	
Length inches (millimeters)	Tolerance inches (millimeters)
Up to 12 (304.8)	+1.00 (25.4)
12 to 36 (304.8 to 914.4)	+2.00 (50.8)
36 to 120 (914.4 to 3.05 meters)	+4.00 (101.6)
120 (3.05 meters)	+4.00 (101.6) per 120 (3.05 meters) or part there of



Continued product improvement necessitates that MEGGITT reserve the right to modify these specifications without notice. MEGGITT maintains a program of constant surveillance over all products to ensure a high level of reliability. This program includes attention to reliability factors during product design, the support of stringent Quality Control requirements, and compulsory corrective action procedures. 010121



Note: Due to continuous process improvement, specifications are subject to change without notice. TCO Review # 317