

1X2 DCL LAUNCHER

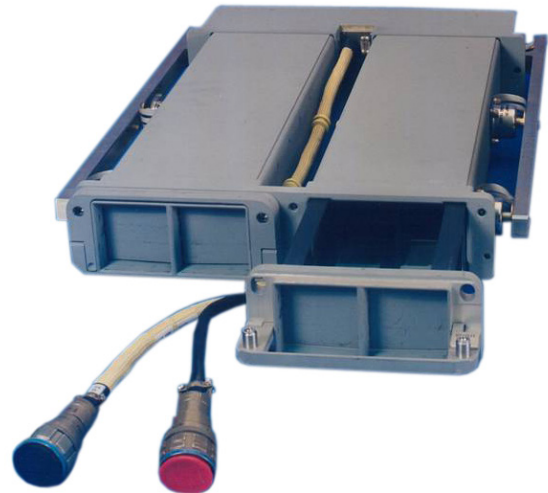

Product description

Parker Meggitt Defense Systems has a family of shock isolated -launchers that support pyrotechnic jettison of expendables into the airstream. These launchers were specifically designed to support tethered expendables with care to protect the tether.

Launchers can be built to accommodate several configurations (1 to 4 expendables have been built and qualified to date). Launchers support a family of magazines and incorporate a carrier qualified blind-mate high voltage and fiber optic connector. Launchers pass dozens of discrete, several high voltage and one optical fiber connection per expendable location. Launchers support two pyrotechnic cartridge types and are shock isolated to protect the payload electronics from high frequency vibration.

Key features and benefits

- Pyrotechnically driven launchers
- O-rings seal in hot gases – system is explosive-atmosphere-safe
- No FOD
- 2- and 3-segment telescoping pistons can provide higher launch velocity if necessary
- Alternate methods to retain payload and resist vibration and shock loads until squib fires:
 - Tension screw, with designed failure load
 - Shear screw(s), with designed failure load
 - Frangible end cap
- All MDSI launchers use standard pyrotechnic

Applications

- Support pyrotechnic jettison of expendables into the airstream



Parker Meggitt Defense Systems
9801 Muirlands Blvd.
Irvine, CA 92618
+1 (949) 465 7700
www.meggittdefense.com

1X2 DCL LAUNCHER

Specifications

weight	10 lbs
height	3.59 in
width	9.47 in
length	24.10 in
Specifications do not include rails (optional).	
MDSI has designed, fabricated and tested 17 different pyrotechnically-driven launchers	
8 MDSI launchers reached operational status	
6 MDSI launchers are currently operational with the US military	
1 MDSI launcher is currently operational with a foreign military organization	

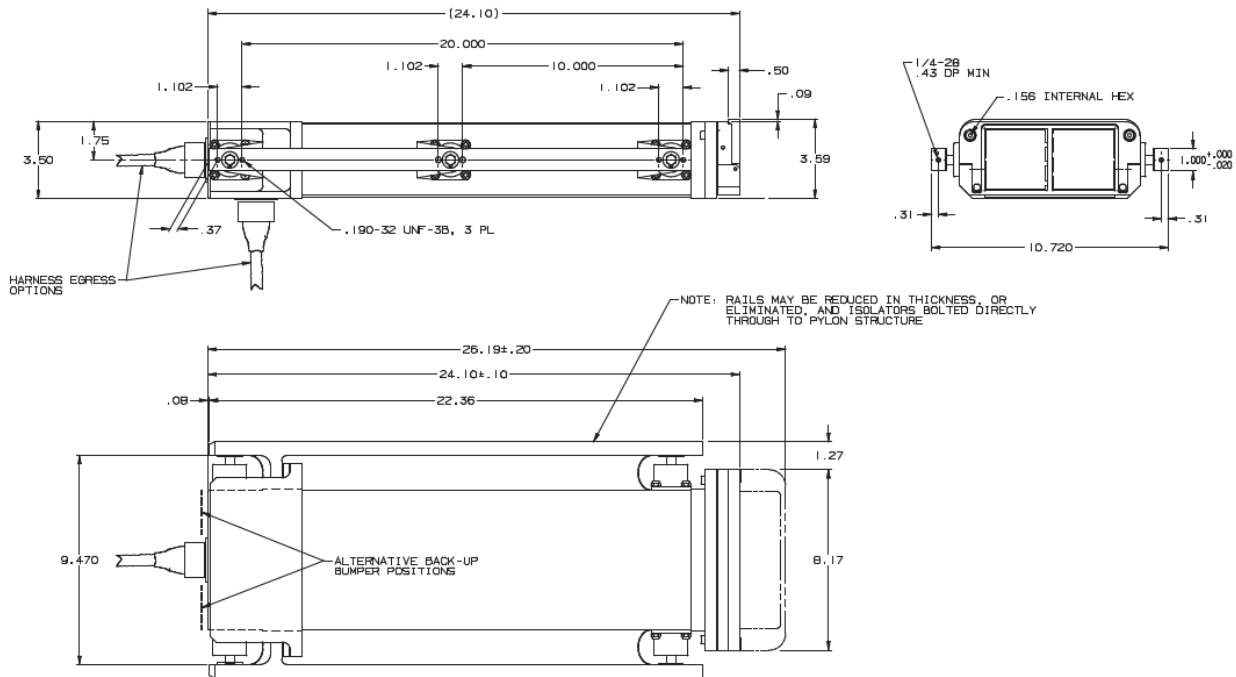

Note: Due to continuous process improvement, specifications are subject to change without notice. TCO Review # 115